

30 DECEMBER 1986

**TOPOGRAPHIC SUPPORT SYSTEM
PLATE PROCESS SECTION
MODEL ADC-TSS-19
NSN: 3610-01-105-1743**

Reference TM 5-3610-259-14 and C9100-IL

Intervals and the related manhour times are based on normal operation. The task hour time specified is the time you need to do all the services prescribed for a particular interval. Decrease the interval and lubricate more frequently if your lubricants have been contaminated or you are operating under adverse conditions, including longer-than-usual operating hours. The intervals between lubrications may be extended during periods of low activity, but only if adequate precautions have been taken. The lowest level of maintenance authorized to lubricate a point is indicated by the following symbol:
Operator/Crew (C). Clean all fittings, plugs, and

caps before removal and/or lubrication. If possible, exercise moving parts to distribute lubricant evenly. Lubricate all oil can points after washing or fording.

"Reporting errors and recommending improvements. You can help improve this manual. If you find any mistakes or if you know of a way to improve the procedures, please let us know. Mail your letter or DA Form 2028 (Recommended Changes to Publications and Blank forms) direct to: Commander, U.S. Army Troop Support Command, ATTN: AMSTR-MCTS, 4300 Goodfellow Boulevard, St. Louis, Mo. 63120-1798. A reply will be furnished to you.

LUBRICANT ● INTERVAL

INTERVAL ● LUBRICANT

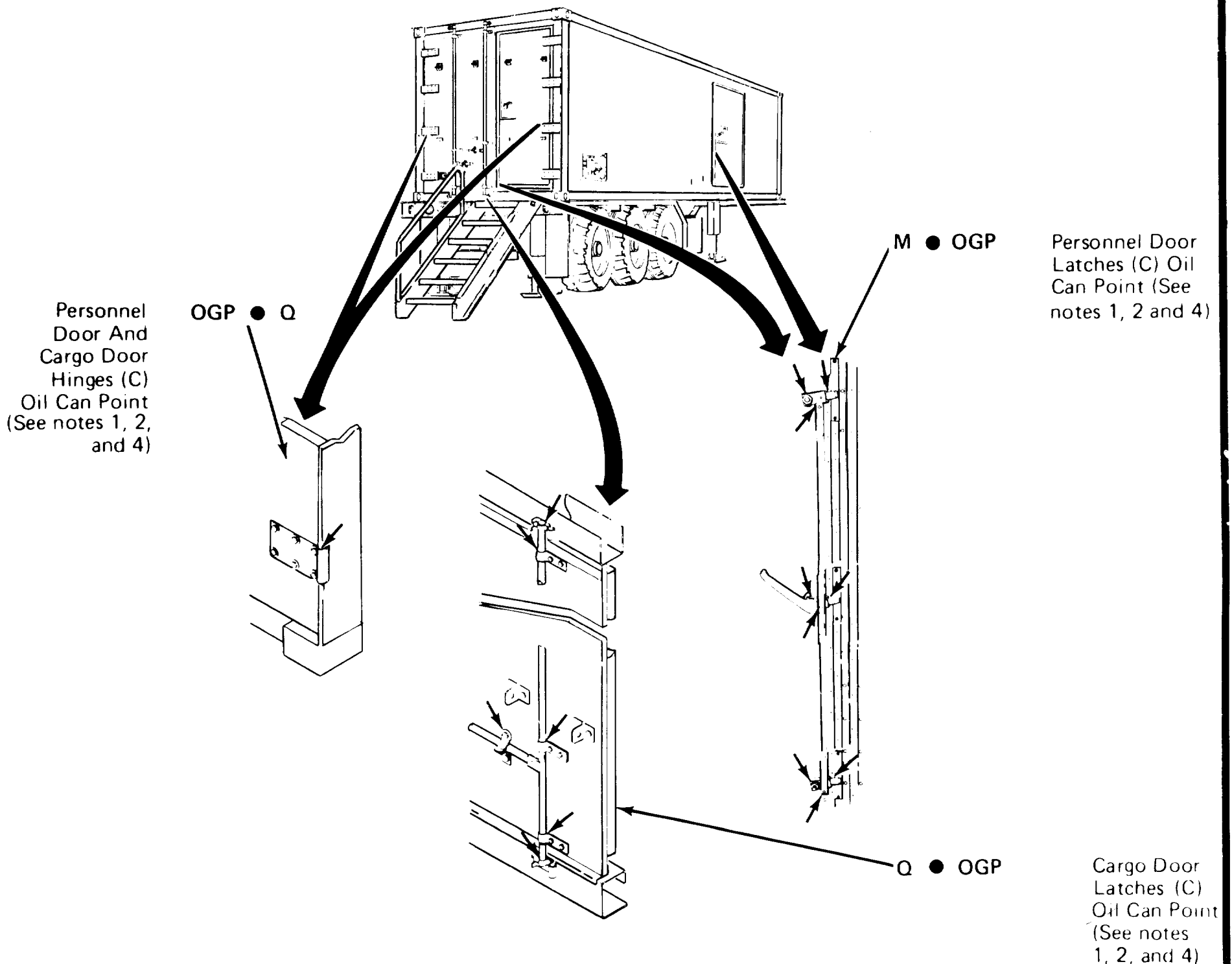

LUBRICANT ● INTERVAL

INTERVAL ● LUBRICANT

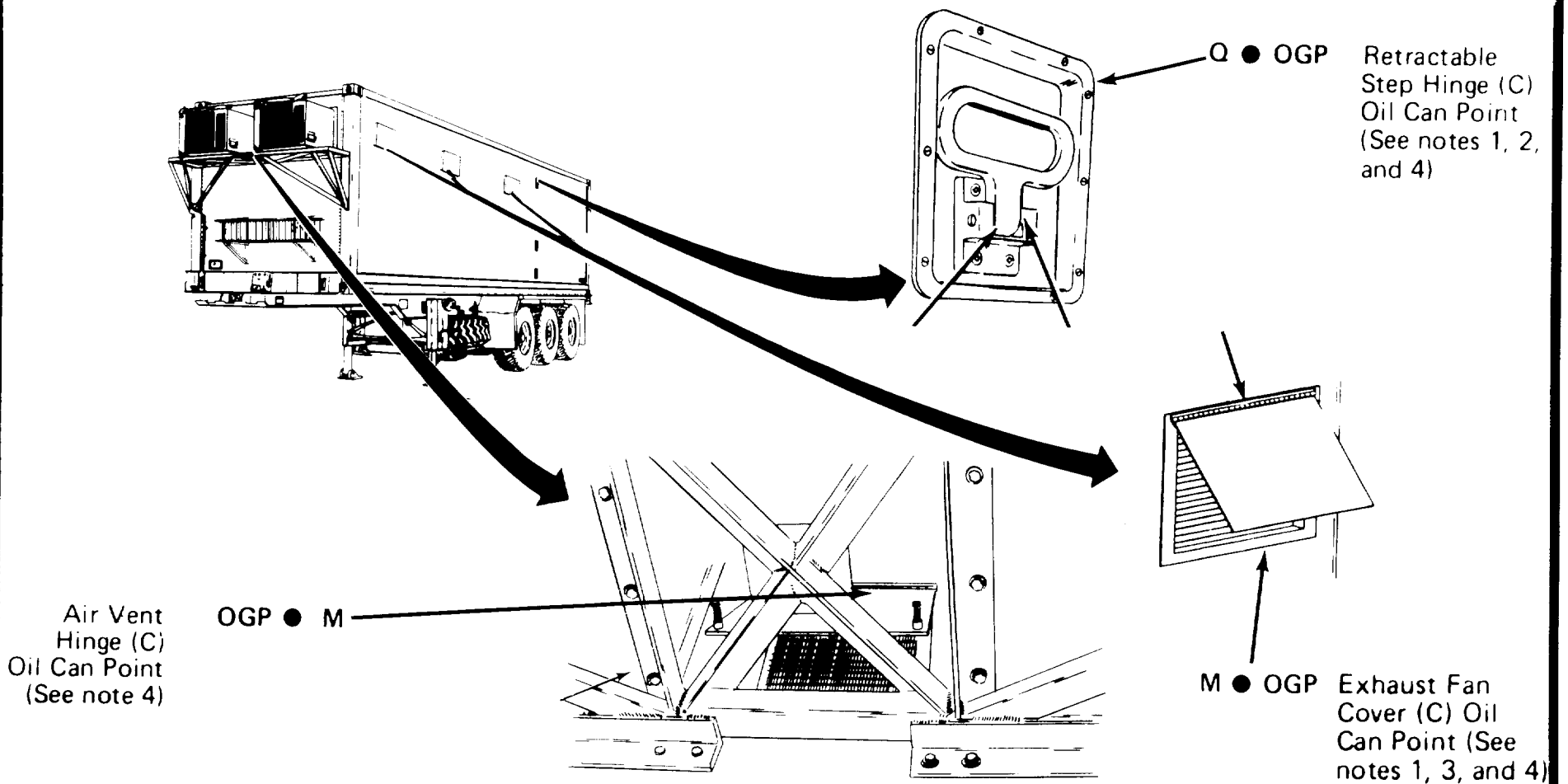

TOTAL TASK-HR		TOTAL TASK-HR	
INTERVAL	TASK-HR	INTERVAL	TASK-HR
M	0.3	Q	0.6

KEY

LUBRICANTS	EXPECTED TEMPERATURES	INTERVALS
OGP (MIL-L-7870) LUBRICATING OIL, GENERAL PURPOSE, LOW TEMPERATURE <hr/> PERSONNEL DOOR AND CARGO DOOR HINGES <hr/> PERSONNEL DOOR LATCHES <hr/> CARGO DOOR LATCHES <hr/> RETRACTABLE STEP HINGE <hr/> EXHAUST FAN COVER <hr/> AIR VENT HINGE	All Temperatures	M MONTHLY Q QUARTERLY

NOTES

1. Before lubricating, wipe all points free of dirt, grease, or dust.
2. Wipe all surplus oil from surfaces after lubrication.
3. When lubricating hinges, be sure oil covers entire length of hinge.

Copy of this Lubrication Order will remain with the equipment at all times; instructions contained herein are mandatory.

By Order of the Secretary of the Army:

JOHN A. WICKHAM, JR.
General, United States Army
 Chief of Staff

Official:

R. L. DILWORTH
Brigadier General, United States Army
 The Adjutant General

DISTRIBUTION:

To be distributed in accordance with DA Form 12-25A, Operator and Organizational Maintenance requirements for Plate Process Section, Topographic Support System, Semitrailer Mounted (10536-2).